

DELRAN TOWNSHIP FIRE DISTRICT #1
BOARD OF FIRE COMMISSIONERS
CAUCUS MEETING
June 10, 2025

The caucus meeting of the Board of Fire Commissioners of the Delran Township Fire District No. 1 was held on Tuesday evening June 10, 2025 at the Fire District Office.

President Joseph Parento, commencing with the flag salute, called the meeting to order at 7:30 pm.

The President announced that this meeting is being conducted within the provisions of N.J.S.10-4.6 to N.J.S. 10:4-41 titled Open Public Meetings and that the time and place has been posted on the bulletin board of the Municipal Building and was advertised in the Courier Post on February 6, 2025.

Other members of the Board and appointed persons present were Commissioners James Turcich, James Bauer, Anthony Quaciari, and Joseph Seybert. Also present were: Chief Joseph Cunningham, Sr., Deputy Chief Kevin Peak, 231 Batt. Chief Scott Seybert, 232 Captain CJ Francis, 231 Lt. Ralph Bensel, Clerk Elizabeth Briggs.

A motion was made by Commissioner Quaciari, which was seconded by Commissioner Turcich, to approve the May 27, 2025 meeting minutes. The Board was polled, all AYES. The motion was approved.

COMMUNICATIONS: Nothing to report.

SECRETARY: Nothing to report.

CHIEF: Report is attached.

Pump testing was complete. 2311 failed so once it is fixed we will have it tested again.

DEPUTY CHIEF: Report was read and is attached.

STATION 231 BATTALION CHIEF: Nothing to report.

STATION 232 BATTALION CHIEF: Not in attendance.

STATION PRESIDENTS: Not in attendance.

OTHER LINE OFFICER'S REPORTS: 232 Captain Francis-nothing to report

231 Lt Bensel- we are working on putting the numbers on the trucks. We ordered more vinyl.

FIRE OFFICIAL/ FIRE PREVENTION: Not in attendance.

TRUSTEES: 232 Trustees- we are still looking into the pricing for the 231 computer/audio system so they can move forward with 232s system.

231 Trustees are working on blinds and the side doors specs.

FIRE POLICE: The next meeting is in Willingboro.

OEM- Not in attendance.

PUBLIC RELATIONS: The department recently received a donation of 42 cases of facemask wash. We received a call today requesting the squirt to come to the summer camp in July and August. The department has been adding our training videos to our social media.

FIRE EQUIPMENT: The lights for the helmets were ordered.

OFFICE SPACE & EQUIPMENT: We are looking to purchase new computers and know we need at least 3 more for the Bridgeboro station. We will find out how many the Chester Ave Station needs.

MASTER PLANNING: Nothing to report.

UNIFORMS: We have 1 request.

APPARATUS: 2315 is out getting the ladder worked on. 2319's oil leak is fixed.

WEBSITE: Nothing to report.

SAFETY: Nothing to report.

BUILDING & GROUNDS: We are working on the HVAC project/bid. We need to have the measurements for the stove for the HVAC project so he can order the proper hood system. Commissioner Parento requested an executive session later in the meeting to discuss the contract with the other commissioners before moving forward and awarding the bid.

GRANT: Nothing to report.

OLD BUSINESS: Nothing to report.

TREASURER'S REPORT: Quickbooks will be updating their system. Both stations use Quickbooks so they are looking at the new options and looking at what will work for them.

BILLS FOR PAYMENT: The bills for this evening are \$118,527.19. A motion was made by Commissioner Turcich and seconded by Commissioner Seybert to pay all bills present. The Board was polled. All AYES. The motion was carried.

NEW BUSINESS: Nothing to report.

PUBLIC COMMENTS: Nothing to report.

COMMISSIONERS COMMENTS:

A motion was made by Commissioner Bauer and seconded by Commissioner Quaciari to go in to an executive session to discuss the contract for the HVAC Project at 7:46PM. The Board was polled. All AYES. The motion was carried. The executive session ended at 8:02PM and the regular meeting agenda continued.

The HVAC Project was discussed. The materials for the project will be stored in the bay closest to the hallway. The stove will be 60" which they needed to know for the hood system. A letter from Pete Honeyford from PMH sent a letter recommending to move forward with LGB Mechanical. A motion was made by James Bauer, seconded by Anthony Quaciari, to approve Resolution 2025-12 awarding the bid to LGB Mechanical. The Board was polled. All Ayes. The motion was approved.

There was no further business to discuss so a motion was made by Commissioner Seybert and seconded by Commissioner Bauer to adjourn the meeting at 8:17PM. The Board was polled. All AYES. The motion was carried.

Respectfully submitted,

Elizabeth S. Briggs

Elizabeth S. Briggs

DELRAN TOWNSHIP FIRE DISTRICT #1
BOARD OF FIRE COMMISSIONERS
EXECUTIVE SESSION MEETING
June 10, 2025

The executive session began at 7:46 pm. There was a discussion about the contract for the HVAC project and the funds for said project. The original expectation for cost was about \$750,000. The lowest bid from LGB Mechanical Inc. Was \$863,000. Since the township is funding the project we needed to make sure the additional unexpected amount will also be covered by them. The executive session was closed at 8:02pm.



June 10, 2025

Elizabeth Briggs
Delran Fire District #1
900 Chester Avenue
Delran, NJ

REF: Fire Company #2 - HVAC Renovation
Contract Award Recommendation

Dear Ms. Briggs:

We are in receipt of the bids for the Fire Company #2, HVAC Renovation Project, and have sorted those bids by amount. The apparent low bid was submitted by LBG Mechanical, Inc. from West Berlin, NJ. Their bid was for \$863,000.00.

We have reviewed their documentation and found no deviations. We have met with their representative at the project job site and reviewed the scope of work. They appear to have a good understanding of the scope and included all major scope items, and took no exceptions. They include a Performance Bond.

We are about to obtain a financial background report on the corporation. Short of a problem with that, we would recommend contracting LGB Mechanical for the HVAC Renovation project at Fire Company #2.

Sincerely,

A handwritten signature in black ink, appearing to read "P. Honeyford", with a long horizontal flourish extending to the right.

Peter M Honeyford, PE

12178 NORTH CHURCH STREET, MOORESTOWN, NEW JERSEY 08057
(856)273-0554 FAX (856)273-7701
E-MAIL: PMH@PMH-ASSOCIATES.COM

CC:

I:\PMHproj\23\230098 Kitchen Hood - Delran FD - PMHCONSTRUCTION\CONTRACT\230098.03LTR01_award rec_250610.doc

New features found only on the Platinum Series offer unsurpassed power and performance for discerning home chefs who demand restaurant-quality results.

\$1,900

PRODUCT FEATURES

- PrimaNova™ power burner delivers 25,000 BTUs of intense heat
- All burners including Interchangeable Griddle and Charbroiler
- Gentle 130° simmer burner
- New PowR Oven™ provides 40% faster preheating and 30% increase in oven efficiency
- Extra-large oven with True European Convection 1850° Infrared Broiler
- Accommodates full-size commercial 18" x 26" baking sheet
- Available in 1,000+ colors and finishes

SPECIFICATIONS

Range Dimensions: 59.875"W x 24"D x 36.75"H
 Oven Interior: 26.438"W x 20"D x 15"H
 Top Burner Rating: 25,000 BTUs
 Simmer Burner Rating: 9,000 BTUs
 PowR Oven™ Burner Rating: 25,000 BTUs
 Infrared Broiler Rating: 15,000 BTUs
 Electrical Requirements: 120V, 60Hz, 15 AMPs, 1 PH
 (Unit must be on a Non-GFI, dedicated outlet)
 Operating Gas Pressure: NAT: 5.0" WC, LP: 10.0" WC
 Gas Line Size: 3/4"
 Installation Clearance: 0" Side Cabinet, 0" Back Wall

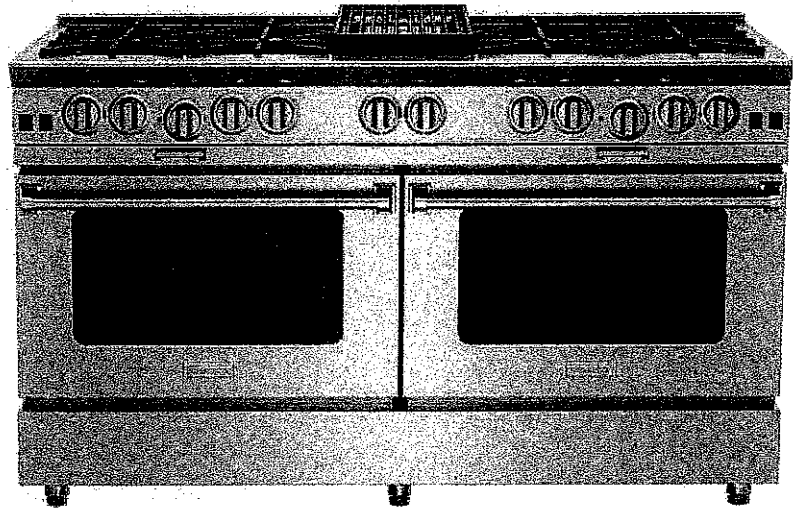

MODEL CONFIGURATION

Ten Burners with Interchangeable Griddle Charbroiler **BSP6010B**

BURNER CONFIGURATION

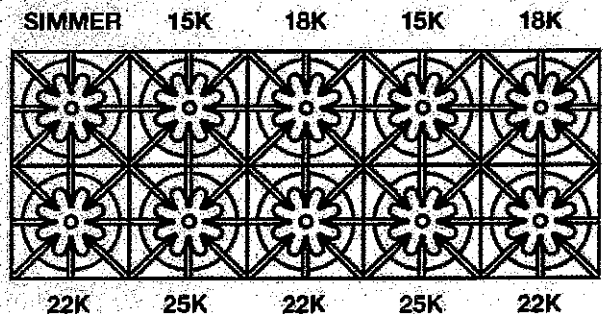

ADDITIONAL CUSTOMIZATION OPTIONS

- Burner configurations
- Backguards
- Knob colors
- Trim options

*Ranges
 Delivery DATE
 LATE JUNE ?*

All specifications subject to change without notice.
 Contact BlueStar Customer Service at (800) 449 - 8691
 prior to installation or site preparation.

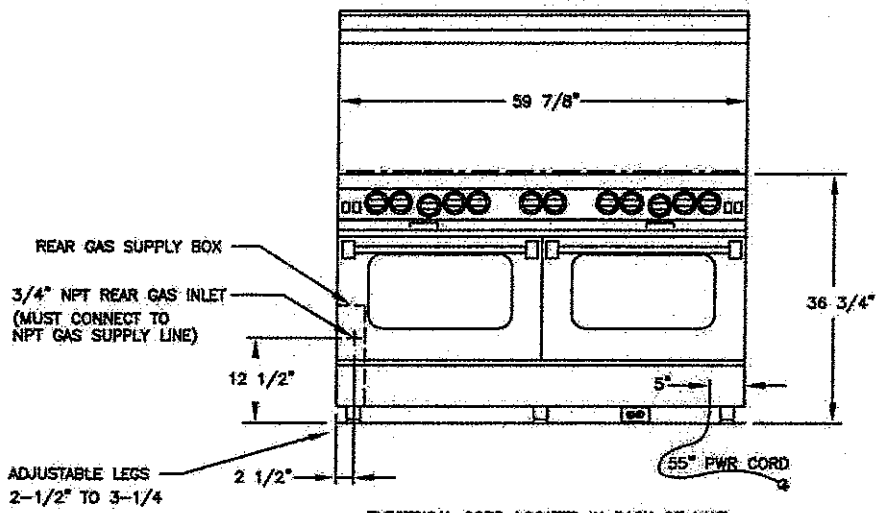

ELECTRICAL CORD LOCATED IN BACK OF UNIT
LOCATION OF ELECTRICAL OUTLET MUST
NOT BE HIGHER THAN 3" FROM FLOOR IF LOCATED BEHIND
THE UNIT OR CAN BE LOCATED IN AN ADJOINING CABINET.

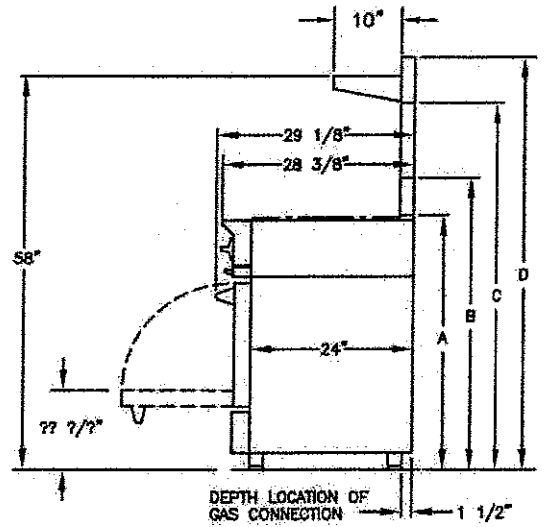

A - ISLAND TRIM HEIGHT - 37 1/2"
B - 6" STANDARD BACKGUARD HEIGHT - 43"
C - 17" BACKGUARD HEIGHT - 54"
D - HIGH SHELF BACKGUARD HEIGHT - 60 3/4"

RELATED PRODUCTS

VENTILATION

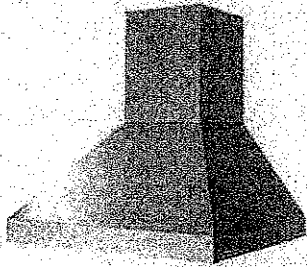

SALAMANDER BROILER

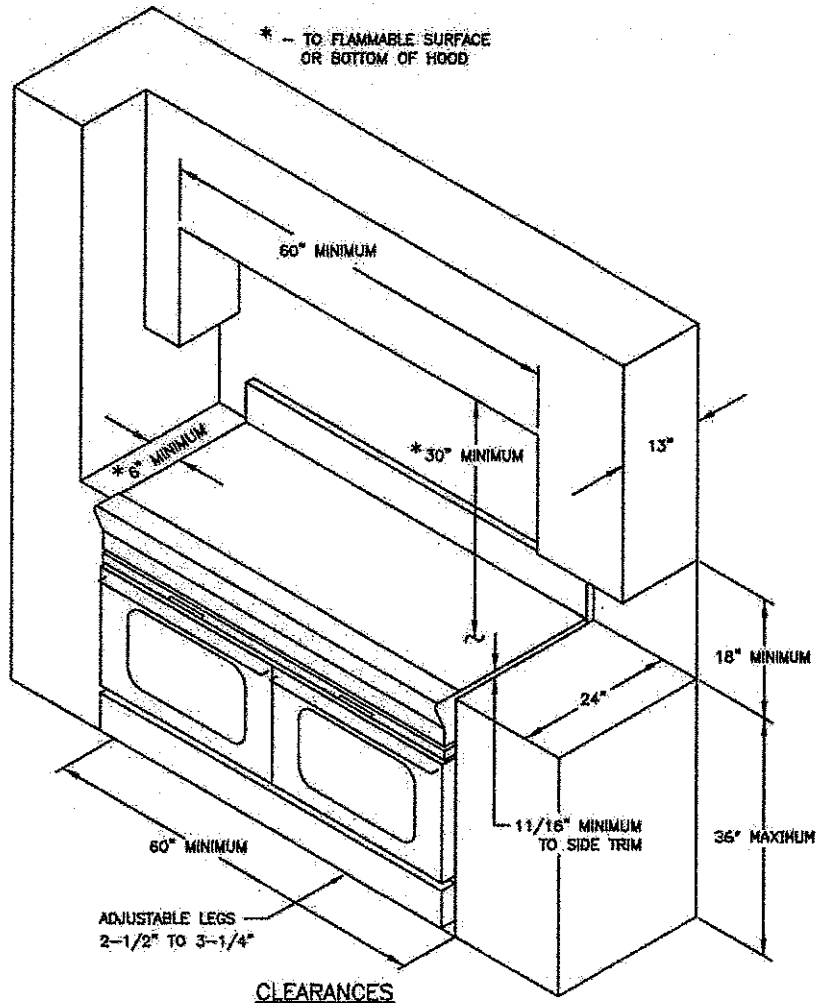
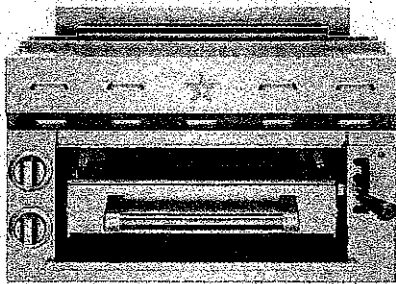



DELTRAN FIRE DEPARTMENT

P.O. Box 1007

Delran, New Jersey 08075

Office: 856-461-5474 Fax: 856-461-9005 *Emergencies Dial 9-1-1*

Delran Fire Department Deputy Chiefs Report

June 10, 2025

Currently we are at 315 calls for service.

Some notable incidents since the last meeting:

May 30th – DFD was dispatched to and responded to Riverside for a reported structure fire. Same was found to be a pot on the stove that had caught fire and was extinguished. Scene was reduced and units were released.

June 2nd – Marine units and rescue units were called to the area of 2 Burlington Ave for a report of a person who jumped into the water. Patient was in care prior to need of FD units. Held with District 11 units.

June 6th – R2329 responded to Cinnaminson for a reported structure fire. Crews arrived and assisted with any on scene needs that arose. Scene was reduced down to units required and Delran was cleared.

Department officers met to round out the second half of the years drill schedule for the department.

Kevin F. Peak
Deputy Chief; Fire Operations
Delran Fire Department; Delran Fire District #1



DELTRAN FIRE DEPARTMENT

P.O. Box 1007

Delran, New Jersey 08075

856-461-5474 Fax 856-461-9005

Emergencies Dial 9-1-1

June's Chief Report 2025

1. The Department answered 313 calls to date.
2. The annual apparatus pump & ladder testing was completed copies are attached.
3. Hose testing will be getting done this week.
4. I received a phone call from the NJDFS about the acquired structure training we did on June 2nd, 2025. Apparently PEOSH saw the video and thought there was an active fire inside the dwelling and reported us to the Division. I spoke with the head of training for the division and stated we were using an extinguisher prop inside the structure. Case close per the division.
5. PEOSH is monitoring social media accounts to catch people with facial hair.
6. Walt Bauer and I attended a Homeland Security Seminar at Kean University on Thursday June 5th, 2025. The seminar was all about the Club Cup Soccer Tournament taking place this week around the country and the FIFA World Cup Soccer Tournament taking place in Philadelphia and North Jersey from June 11- July 19th 2026. Met life stadium will be hosting 16 games between the two tournaments. More info will follow.
7. The department has 6 members graduating from High School and 1 member will be graduating from Camden County Police Academy.
8. I'm sure we all saw the news over the last week about the potential for mass casualty incidents. Moorestown yesterday with IED making materials, Philadelphia last week where the kid was going to shoot up the school and what's going on in Los Angeles with the riots. This could happen anywhere please be vigilant and if you see something call the proper authorities.
9. The new FM and Command vehicles are in the process of being built. And I will receive an email when they arrive at Winner Ford to have the upfit done.
10. No news on the AFG Grant yet and the Fire Prevention and Safer Grants are now open.

Respectfully Submitted

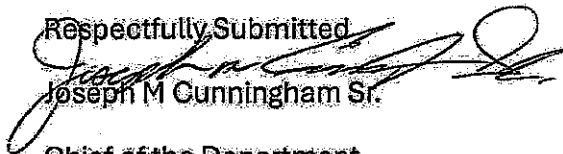

Joseph M Cunningham Sr.

Chief of the Department

Delran Township Fire District #1